

FIDLOCK®

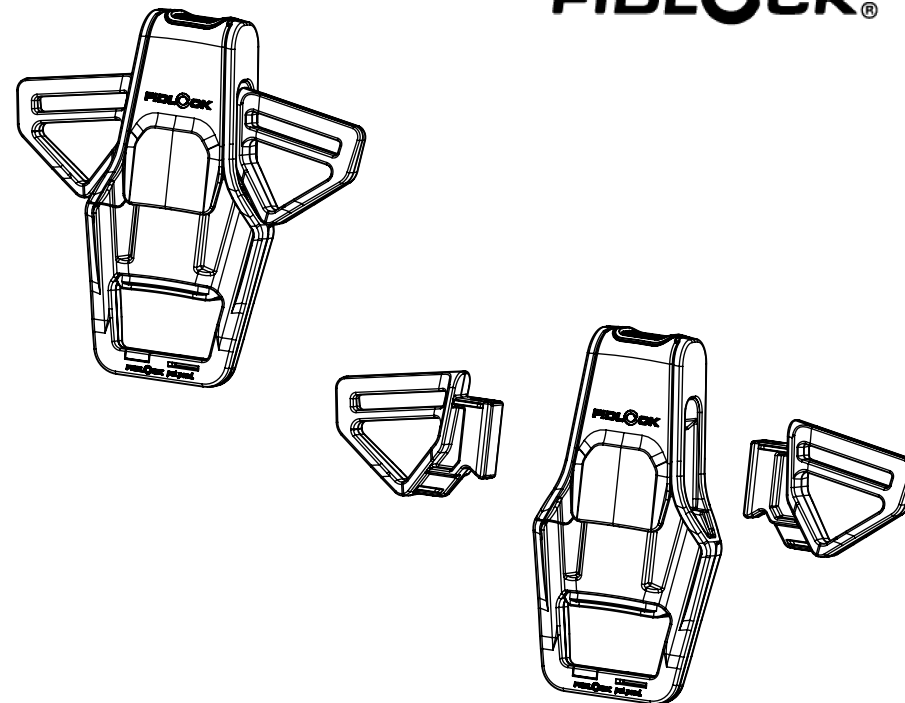

Double Action:
 1) press 1st action button to release 2nd action button
 2) press 2nd action button to open closure

PRODUCT	JUNIOR press double 3-point lock
APPLICATION	strollers, bicycle child seats
OPENING	double press
MATERIAL	PA66GF15 / POM
COLOUR	Black / Grey
COLORABLE	yes
WEIGHT	~57 g
LOAD CAPACITY	40 kg
GENERAL NOTES	<p>Developed for strollers and child-seats with 3-point strap systems, e.g. bicycle seats (suitability depending on the implementation of the fastener on the product).</p> <p>Not for use on child car seats. Use for safety-related applications only after successful suitability testing by the manufacturer.</p>

ARTICLE NO.	F9420-000001(BLK)
SCALE	1:2
DATE	16.07.2021
AUTHOR	Lasse Hiller

patented technology.